

solaire X3-GRAND



Features



High Efficiency

- Up to 99.03% efficiency
- 500~1500Vdc MPPT range
- Max. 75A DC input per MPPT, optimized for high-power solar panel



Intelligent Design

- IV curve scan
- 24 hours monitoring
- Night-time SVG voltage regulation support



Assured Safety

- AC terminal temperature detection
- AFCI support (optional)*
- IP66 ingress protection
- Effective Anti-PID protection (optional)*
- Optional Type I+II SPD on DC side & Type II SPD on AC side*



Flexible Adaptability

- 6 MPPTs, 5 strings per MPPT for precise power
- Power line communication (PLC)

Efficiency Curve

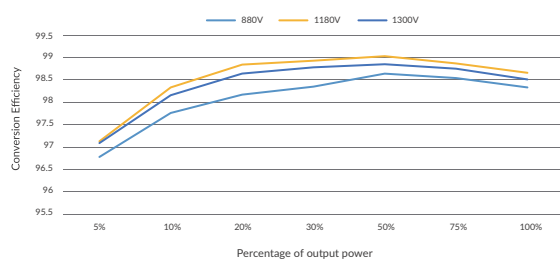

Circuit Diagram

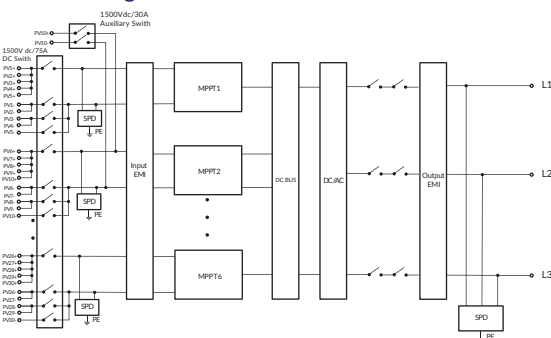

PV INPUT				
Max. PV input power per MPPT	450 kWp	480 kWp	499.5 kWp	525 kWp
Max. PV input voltage ^①	1500 V			
Rated PV input voltage	1080 V			
Operation voltage range	550 ~ 1500 V			
MPPT voltage range ^②	500 ~ 1500 V			
Start up voltage	550 V			
No. of MPP trackers / strings per MPP tracker	6 / 5			
Max. input current per MPPT	75 A			
Max. input short circuit current per MPPT	115 A			
AC OUTPUT				
Rated output power	300 kW	320 kW	333 kW	350 kW
Rated output current	216.6 A	231 A	240.3 A	252.6 A
Max. output apparent power	300 kVA	320 kVA	333 kVA	352 kVA
Max. output continuous current	216.6 A	231 A	240.3 A	254 A
Rated AC voltage	3 / PE, 800 V			
Rated AC frequency	50 Hz / 60 Hz			
AC frequency range ^③	50 ± 5 Hz / 60 ± 5 Hz			
Adjustable power factor range	-0.8 lagging to 0.8 leading			
THDi (rated power)	< 3%			
EFFICIENCY				
Max. efficiency	99.03%			
European efficiency	98.80%			
ENVIRONMENT LIMIT				
Ingress protection	IP66			
Operation temperature range	-30 ~ 60°C			
Max. operation altitude	5000 m			
Relative humidity	0 ~ 100% RH (condensing)			
Overvoltage category	Mains: III, PV: II			
GENERAL				
Dimensions (W × H × D)	1225 × 825.5 × 369.1 mm			
Net weight	< 130 kg			
Cooling concept	Smart air cooling			
Communication interfaces	RS485 / PLC / DRM / DI * 1 / DO * 1			
Power consumption (night)	15 W			
Topology	Non-isolated			
Certifications	IEC 61727, IEC 62116, VDE4110, VDE4105, EN50549, NRS097, G99, RD1699, PPDS2020, CEIO-21, CEIO-16, VFR 2019			
AC auxiliary power supply (APS)	Built-in			
PROTECTION				
Over / under voltage protection	Yes			
DC isolation protection	Yes			
DC reverse-polarity protection	Yes			
Grid monitoring	Yes			
DC injection monitoring	Yes			
Back feed current monitoring	Yes			
Residual current detection	Yes			
Over temperature protection	Yes			
AC overcurrent protection	Yes			
AC short-circuit protection	Yes			
Active anti-islanding method	Frequency shift			
Surge protection (DC / AC)	Type II / Type II (optional: DC side Type I + Type II)			
Arc-fault circuit interrupter (AFCI)	Optional			
Anti-PID	Optional			

① The maximum input voltage is the upper limit of the DC voltage. Any higher input DC voltage would probably damage inverter

② Input voltage exceeding the MPPT voltage range may triggers inverter protection

③ The AC frequency range may vary from different country codes